

# KP2HT COMPACTOR



## Self-contained Compactor with Hydraulic Tailgate

### Eliminating Costly Turn-arounds

**K-PAC's KP2HT Self-Contained compactor is an excellent choice where vehicle maneuvering space is limited. Ideal for chute fed and dock fed applications. The innovative high-tail design allows the user to have the advantage of being able to feed it from a dock or from under a chute without having to pay their hauler extra to turn the compactor around. Other features unique to K-PAC's HT model are:**



**Full "closed-cell" neoprene door seal.** To assure clients of a liquid tight door, K-PAC borrowed from the science of the U.S. Navy and uses the same "closed cell neoprene" seal material as used on nuclear submarine doors. The superior seal material along with K-PAC's unique channel and blade system deliver a door rated the best in the industry by knowledgeable users. It's the little details that make K-PAC equipment the best in the industry.



◀ **KP2HT's feature a heavy-duty dual ratchet latch system.**

This pulls the door tightly and evenly against the door seal while an innovative latching system features an adjustable stop to prevent over compression and damage to the seal. And for models *without* the splash pan, we have engineered in an extra set of wheels at the joint between the body and the packing head for a superior seal against leakage and flexing.

**Fully supported and guided ram.** In order to enhance the charge chamber's floor life, cast iron shoes requiring no lubrication run in a formed track on replaceable steel wear strips. In addition, with the use of four sets of pads on the side & the base of the shoes, ram chatter and maintenance is virtually eliminated. AR plate is also used as the floor.



◀ **The Optional Splash Pan** provides added protection by offering the hauler cleaner and safer conditions when emptying the compactor. (*Splash pan as shown on a KP1HT*)



# STANDARD FEATURES

- 10 HP TEFC 3 Phase 208-230-460
- Key Switch, Start & Stop Buttons
- Electrical interlock system prevents operator injury
- Exclusive 41" X 67.5" feed opening for large, cumbersome items
- *Hi-Definition Plasma-cut* provides tighter tolerances for a more refined product
- Multi-cycle timer and 80% light
- Head *sub-floor* allows liquids and sludge to return to the compactor container
- Charge chamber floor is AR plate
- Baffled reservoir reduces heat in the oil and increases pump longevity
- Wheels have an exclusive bolt and pin system for reduced repair costs
- 9 $\frac{3}{8}$  wheels for better support and stability
- Multi-weight ATF Dexron III
- One year parts and labor warranty
- "Center" wheels for a better seal\*
- Meets all ANSI Z245.2 standards
- UL listed control panel (UL)

# OPTIONS

- 20 to 33 cubic yard capacity
- Splash Pan optional design
- 100% Light
- Oil Heater / Oil Level Switch
- Door Auto Start
- Pressure Gauge
- Remote Control
- Cut-off Valve

\*non-splash pan option

## SPECIFICATIONS:

Manufacturer's Rating.....	2.00 cy
WASTEC Rating.....	1.53 cy
Hydraulic Pump .....	12 GPM
Packing Cylinders.....	2-Diagonal, 4.0" X 37", 2.5" Rod
Packing Pressure .....	,250 norm / 45,700 max
Ram Face Pressure.....	norm / 26.8 max PSI
System Pressure .....	,850 norm / 2,100 max PSI
RAM Penetration .....	13"
Clear Top Opening .....	41" X 67.5"
Loading Height .....	46.5"
Cycle Time.....	34 sec.
Hydraulic Tank.....	20 Gallons
Hydraulic Fluid.....	Dexron III ATF
Power Pack Dimensions.....	L 45" X W 18" X H 45.5"
Power Pack Weight – 10 HP / 3 Phase .....	580 lbs.
Power Pack Weight – 5 HP / Single Phase .....	500 lbs.
Liquid Sump height.....	6"

*KP2HT shown with a dock fed design encompassing both hand & toe rails with a gate and interlock system*



*Large rear door with low feed height for safety*



*Rear fed enclosure using a hydraulically raised door and an overhang for added employee safety*

**Ask about our rental & leasing programs!**

**DISTRIBUTED & INSTALLED BY:**



Bay Area Trash Compactor  
1-800-955-0866  
[info@batc-compacts.com](mailto:info@batc-compacts.com)  
[www.batc-compacts.com](http://www.batc-compacts.com)

**MANUFACTURED BY:**

**K-PAC Equipment**  
Division of Krause Corporation  
305 South Monroe Street  
Hutchinson, Kansas 67504-2707  
OFC: (800) 957-2873  
FAX: (800) 443-0863  
[www.k-pac.com](http://www.k-pac.com)



# KP2HT DIMENSIONS

Model	Total Capacity	A <sup>2</sup>	B	C	D <sup>3</sup>	E	F	G	H	I <sup>5</sup>	Weight <sup>4</sup>
KP2HT20	20 Cubic Yards	46.5"	71.5"	120.5"	102"	200.5"	102"	67.5"	41"	182"	8,843 lbs.
KP2HT25	25 Cubic Yards	46.5"	71.5"	153.0"	102"	233.0"	102"	67.5"	41"	182"	9,330 lbs.
KP2HT30	30 Cubic Yards	46.5"	71.5"	185.5"	102"	265.0"	102"	67.5"	41"	182"	9,810 lbs.
KP2HT33	33 Cubic Yards	46.5"	71.5"	205.0"	102"	285.0"	102"	67.5"	41"	182"	10,100 lbs.
KP2HTLP22 <sup>1</sup>	22 Cubic Yards	46.5"	71.5"	153.0"	93.5"	233.0"	102"	67.5"	41"	182"	9,030 lbs.
KP2HTLP29 <sup>1</sup>	29 Cubic Yards	46.5"	71.5"	205.0"	93.5"	285.0"	102"	67.5"	41"	182"	9,700 lbs.

<sup>1</sup> Low profile compactors are manufactured in one-cubic yard increments

<sup>2</sup> Chain understructures with the splash pan option raise the feed height 7.2" to an overall 53.7"

<sup>3</sup> A Chain understructure raises the overall height of the compactor to 105 inches

<sup>4</sup> Weights do not include 580 lbs. for the 10 HP power pack

<sup>5</sup> 182" is based on a Universal Outside Rail understructure

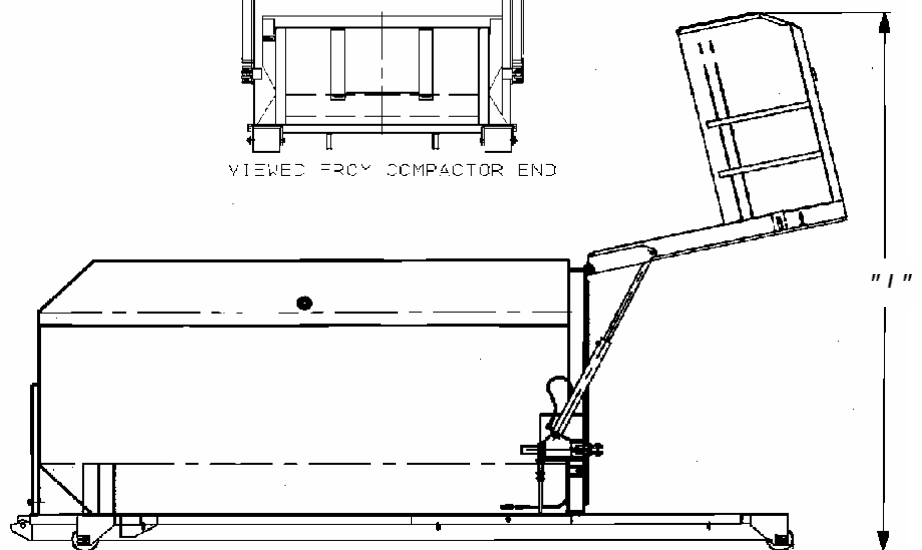
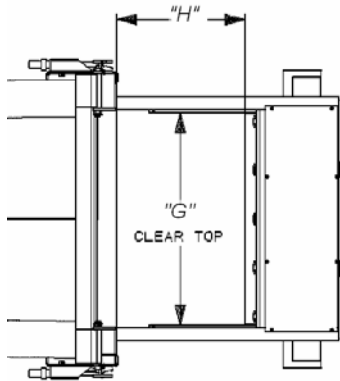
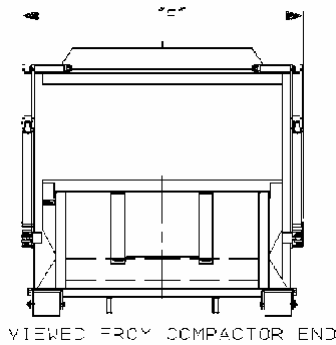
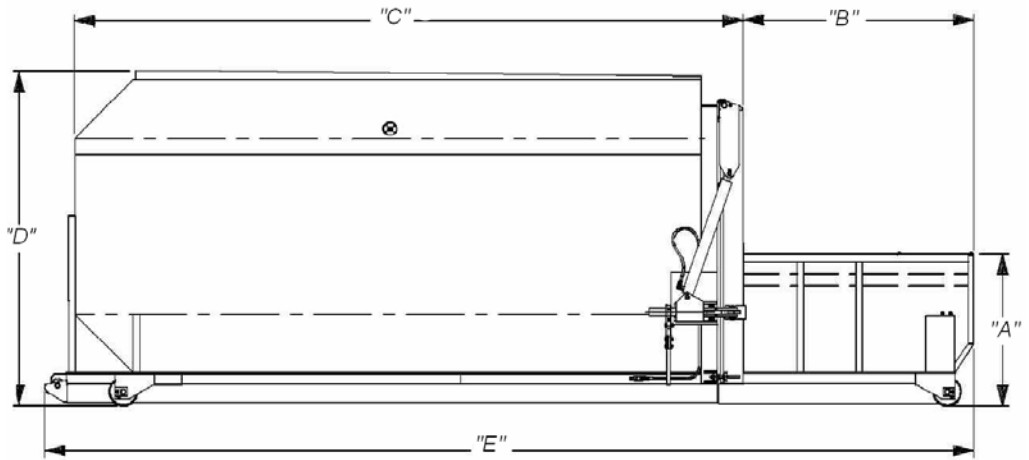

— "The Trend Setters" —

