



X6030

VERTICAL BALER



BENEFITS

- Safety - Bramidan balers are the safest balers on the market
- Longevity - Many Bramidan balers have been operating daily for over 20 years
- Warranty - 1 year labor, 2 year parts, 3 years on the frame

FEATURES

- Ease of use - All wire and twine is pre-fed while the baler is empty
- Ergonomically superior - No reaching behind the baler
- Quiet - at 60-68 Db you'll hardly hear a Bramidan operate
- Automatic bale ejection
- Indicator lights highlight baler functions
- **Free** data cellular communication

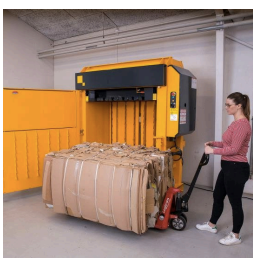

No need to break down large cardboard boxes. The extra wide feed opening allows you to easily toss boxes right into the baler.

SMART APPROACH

- Text/email sent when baler is full
- Text/email to your recycler after a desired number of bales produced
- Sustainability reporting – track how many bales you produce
- Remote service/troubleshooting

manufactured by **BRAMIDAN**[®]



(925) 465-5133 | info@batc-compacts.com | www.batc-compacts.com

© 2019



X6030

VERTICAL BALER

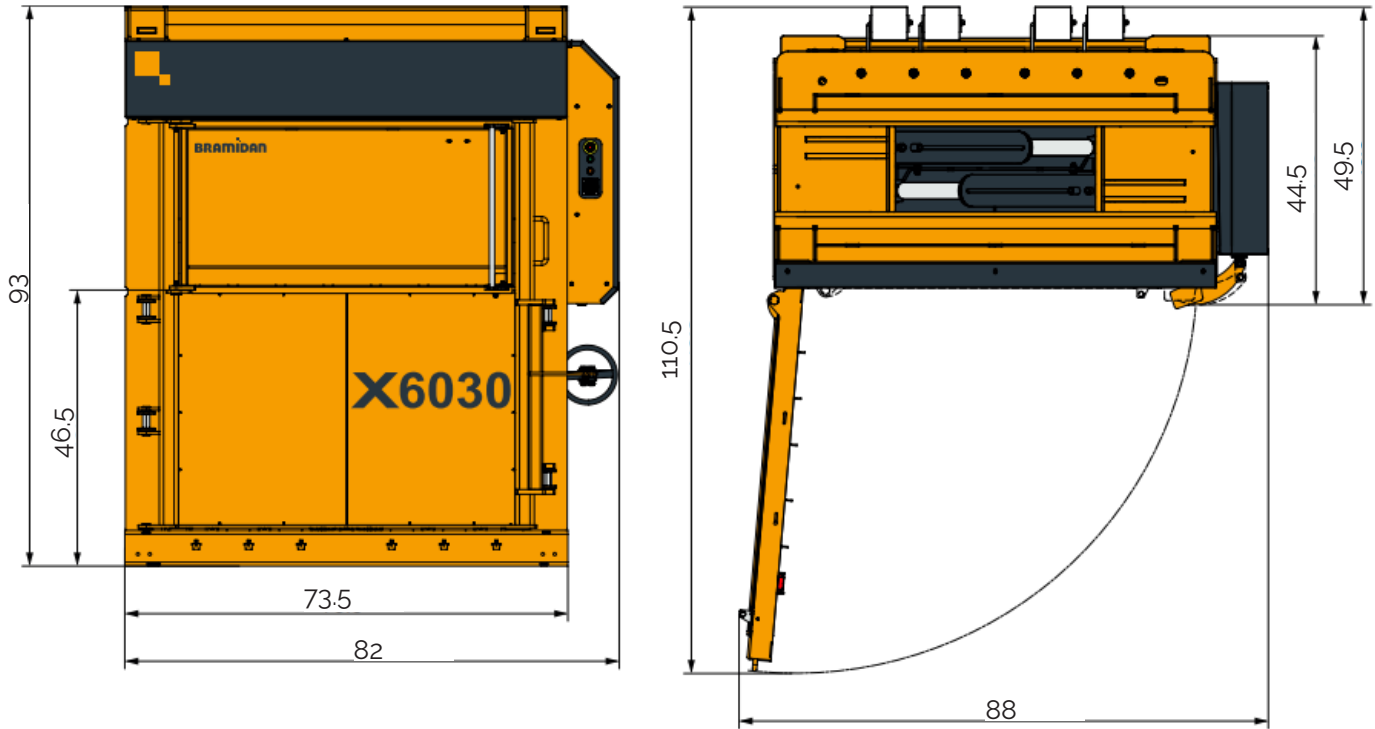

SPECIFICATIONS

Press force (lbs)	88,200
Power supply	208/230/480V 3-phase
Motor (HP)	5.5
Noise level (dB)	59-60
Cycle time (sec)	40
Dimensions (WxDxH) (in)	82x50x93
Weight (lbs)	4,850
Feed opening WxH (in)	60x21
Stroke (in)	93
Number of ties	6
Type of tying	Twine/Steel wire
Full bale light	Yes
Bale size (WxDxH0)	60x30x48
Bale weight OCC (lbs)	800-1,200
Bale weight plastics (lbs)	850-1,300
Bale eject	Automatic

*Specifications may vary 

manufactured by **BRAMIDAN**[®]



(925) 465-5133 | info@batc-compacts.com | www.batc-compacts.com

© 2019