



B5-W

VERTICAL BALER



BENEFITS

- Safety - Bramidan balers are the safest balers on the market
- Longevity - Many Bramidan balers have been operating daily for over 20 years
- Warranty - 1 year labor, 2 year parts, 3 years on the frame

FEATURES

- Ease of use - All wire and twine is pre-fed while the baler is empty
- Ergonomically superior - No reaching behind the baler
- Quiet - at 60-68 Db you'll hardly hear a Bramidan operate
- Automatic bale ejection
- Indicator lights highlight baler functions
- **Free** data cellular communication

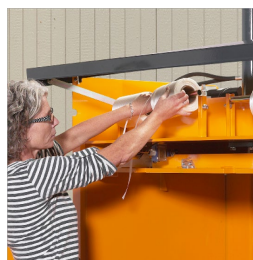

With a wide feed opening of 39 inches, the B5 W is specifically designed for compacting bulky materials.

SMART APPROACH

- Text/email sent when baler is full
- Text/email to your recycler after a desired number of bales produced
- Sustainability reporting – track how many bales you produce
- Remote service/troubleshooting

manufactured by **BRAMIDAN**[®]



(925) 465-5133 | info@batc-compacts.com | www.batc-compacts.com

© 2019



B5-W

VERTICAL BALER

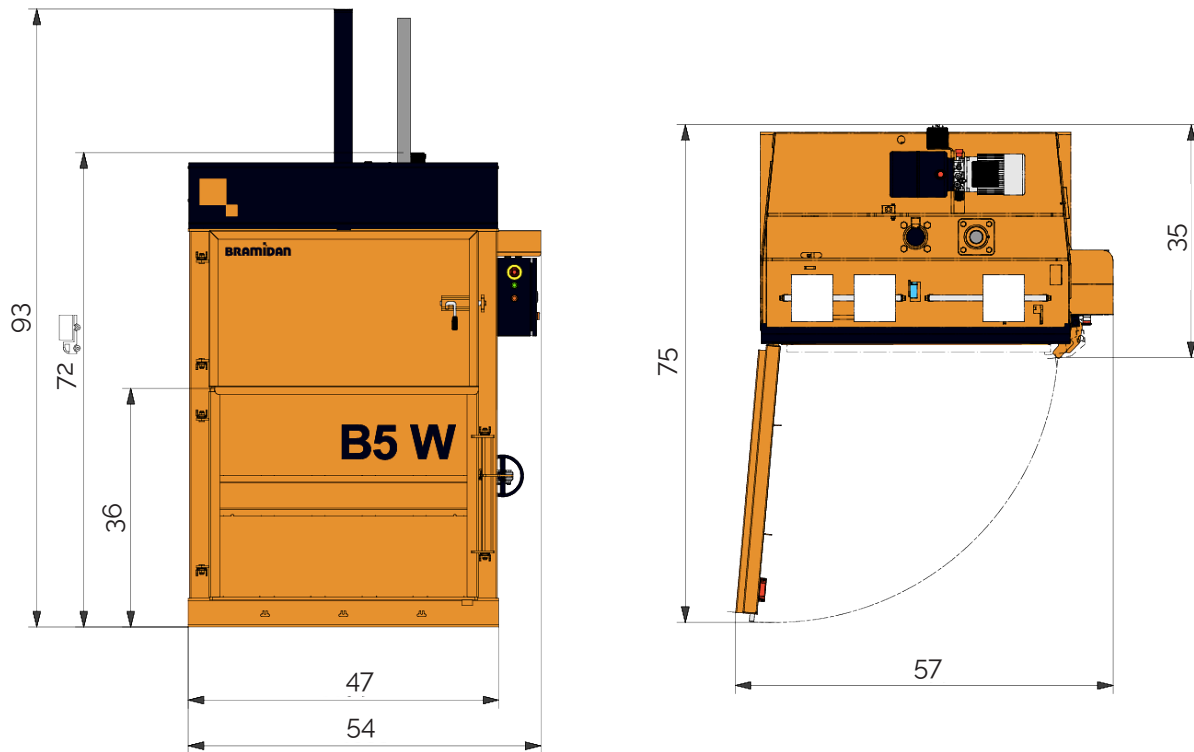

SPECIFICATIONS

Press force (lbs)	11,000
Power supply	110V 1-Phase 60Hz 10/20A
Motor (HP)	1.3/1.8
Noise level (dB)	65-68
Cycle time (sec)	59/39
Dimensions (WxDxH) (in)	54x36x94
Weight (lbs)	1,325
Feed opening WxH (in)	39x21
Load height (in)	36
Chamber height	51
Stroke (in)	30
Bale size (WxDxH0)	39x28x31
Bale weight OCC (lbs)	175-245
Bale weight plastics (lbs)	200-290

*Specifications may vary 

manufactured by **BRAMIDAN**[®]



(925) 465-5133 | info@batc-compacts.com | www.batc-compacts.com

© 2019