



B4

VERTICAL BALER



BENEFITS

- Safety - Bramidan balers are the safest balers on the market
- Longevity - Many Bramidan balers have been operating daily for over 20 years
- Warranty - 1 year labor, 2 year parts, 3 years on the frame

FEATURES

- Ease of use - All wire and twine is pre-fed while the baler is empty
- Ergonomically superior - No reaching behind the baler
- Quiet - at 60-68 Db you'll hardly hear a Bramidan operate
- Automatic bale ejection
- Indicator lights highlight baler functions
- **Free** data cellular communication

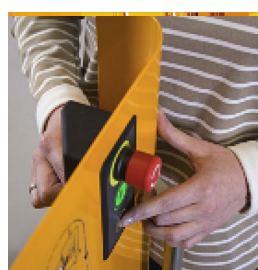

The B4 is unique compared to other small balers. It is packed with extra features including an automatic ejection system and high compaction ratio.

SMART APPROACH

- Text/email sent when baler is full
- Text/email to your recycler after a desired number of bales produced
- Sustainability reporting – track how many bales you produce
- Remote service/troubleshooting

manufactured by **BRAMIDAN**[®]



(925) 465-5133 | info@batc-compacts.com | www.batc-compacts.com

© 2019



B4

VERTICAL BALER

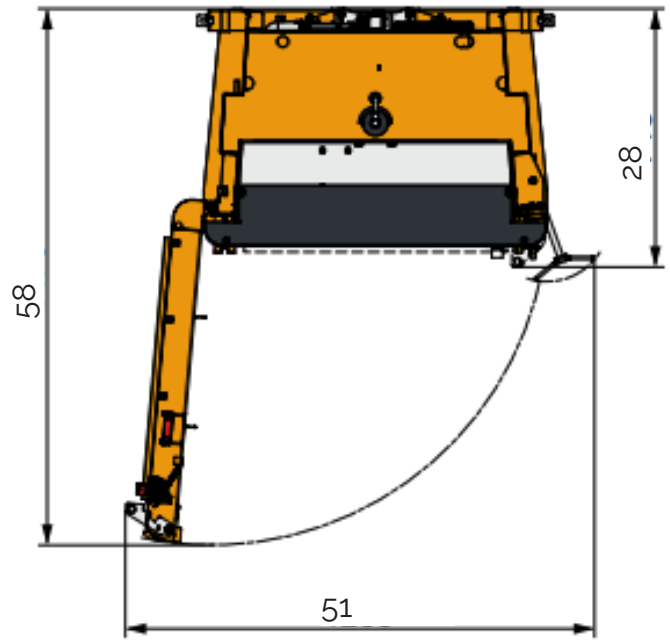
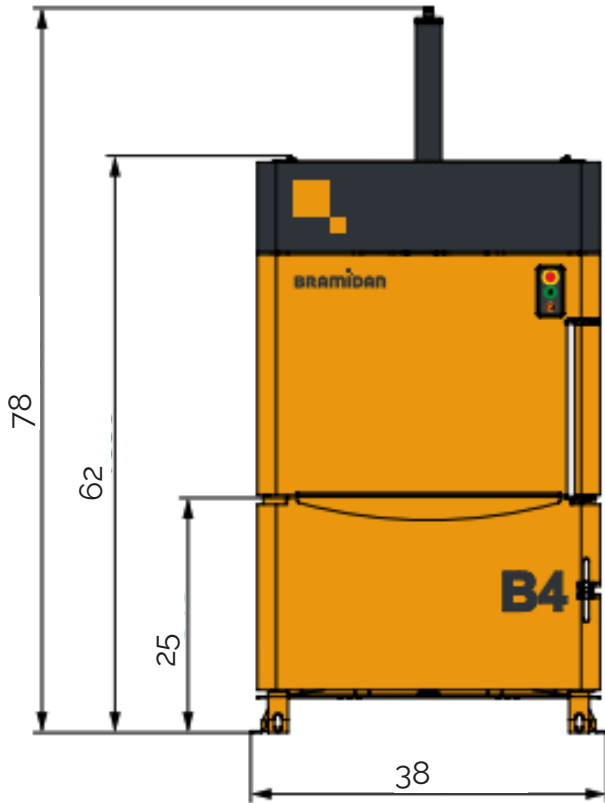

SPECIFICATIONS	
Press force (lbs)	8,800
Power supply	110V 1-Phase 60Hz 10A
Motor (HP)	2.0
Noise level (dB)	57-60
Cycle time (sec)	42
Dimensions (WxDxH) (in)	37x28x78
Weight (lbs)	661
Feed opening WxH (in)	30x18
Load height (in)	25
Chamber height	39
Stroke (in)	26
Bale size (WxDxH0)	30x20x24
Bale weight OCC (lbs)	85-130
Bale weight plastics (lbs)	110-155

*Specifications may vary 

manufactured by **BRAMIDAN**[®]



(925) 465-5133 | info@batc-compacts.com | www.batc-compacts.com

© 2019