



B20

VERTICAL BALER



BENEFITS

- Safety - Bramidan balers are the safest balers on the market
- Longevity - Many Bramidan balers have been operating daily for over 20 years
- Warranty - 1 year labor, 2 year parts, 3 years on the frame

FEATURES

- Ease of use - All wire and twine is pre-fed while the baler is empty
- Ergonomically superior - No reaching behind the baler
- Quiet - at 60-68 Db you'll hardly hear a Bramidan operate
- Automatic bale ejection
- Indicator lights highlight baler functions
- **Free** data cellular communication

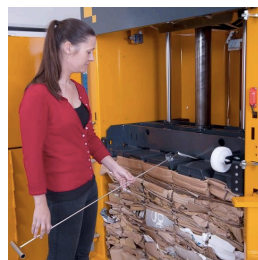

The wide feed opening on the B20 is ideal for large cardboard boxes, plastic shrink wrap, and paper. Retainer dogs inside of the chamber keep material compacted.

SMART APPROACH

- Text/email sent when baler is full
- Text/email to your recycler after a desired number of bales produced
- Sustainability reporting – track how many bales you produce
- Remote service/troubleshooting

manufactured by **BRAMIDAN**[®]



(925) 465-5133 | info@batc-compacts.com | www.batc-compacts.com

© 2019



B20

VERTICAL BALER

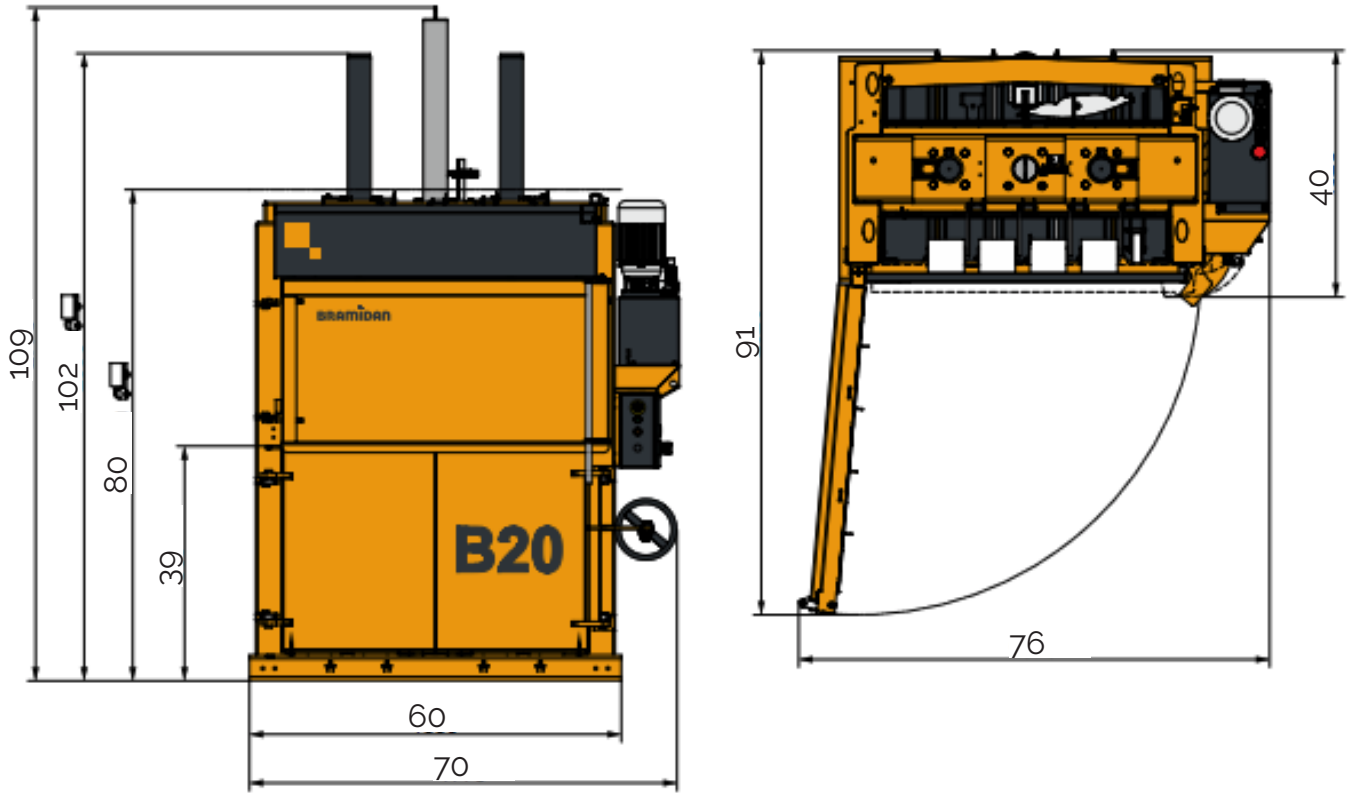

SPECIFICATIONS

Press force (lbs)	44,100
Power supply	208/230/480V 3-phase
Motor (HP)	5.5
Noise level (dB)	62-64
Cycle time (sec)	27
Dimensions (WxDxH) (in)	69x41x109/80
Weight (lbs)	2,750
Feed opening WxH (in)	48x22
Load height (in)	38
Chamber height	56
Stroke (in)	30
Bale size (WxDxH0)	48x30x30
Bale weight OCC (lbs)	450-550
Bale weight plastics (lbs)	550-650

*Specifications may vary 

manufactured by **BRAMIDAN**[®]



(925) 465-5133 | info@batc-compacts.com | www.batc-compacts.com

© 2019