

Vertical balers

B-series



Baler B7242 SD

Large, 72" x 42" baler

The B7242 baler is a heavy duty 72" x 42" baler that will produce bales weighing 1,400+ lbs.

Modern design and high press force

The B7242 is a perfect example of Bramidan's innovative design combined with a press force of over 110,000 lbs resulting in a machine capable of handling significant loads of cardboard or shrink wrap.

Highlights

- 72" x 42" bale
- 1,400+ lbs bale weights
- Large load door for large boxes
- 110,000 lbs of press force
- Front tie off for minimal space consumption
- Compliant with ANSI and UL standards

Optional Extras



Custom colors are available.



BRA-IN fleet monitoring system is included and gives you the ability to monitor the throughput of your machine remotely.



You can use either plastic strapping or baling wire to tie the finished bales.

Product details

Baler B7242 SD



Whisper

30 dB



Refrigerator

50 dB



B7242 SD baler

62-64 dB



Other balers

75 dB

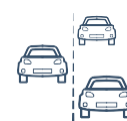

Cars on highway

100 dB



Turbojet engine

160 dB

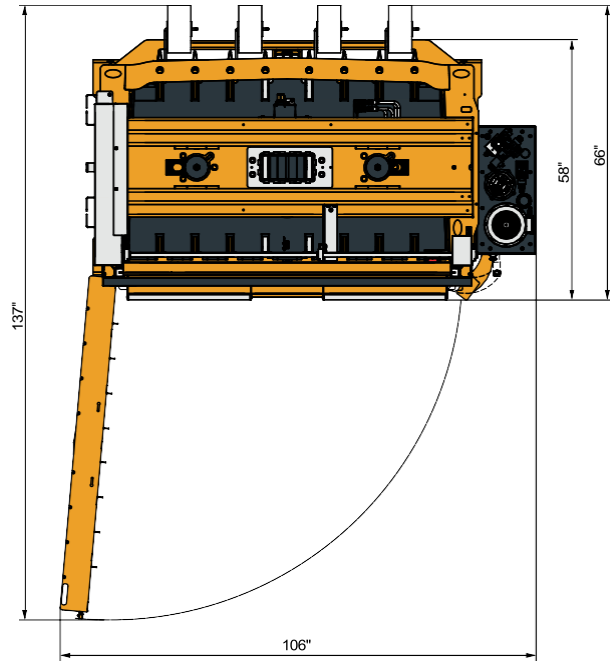
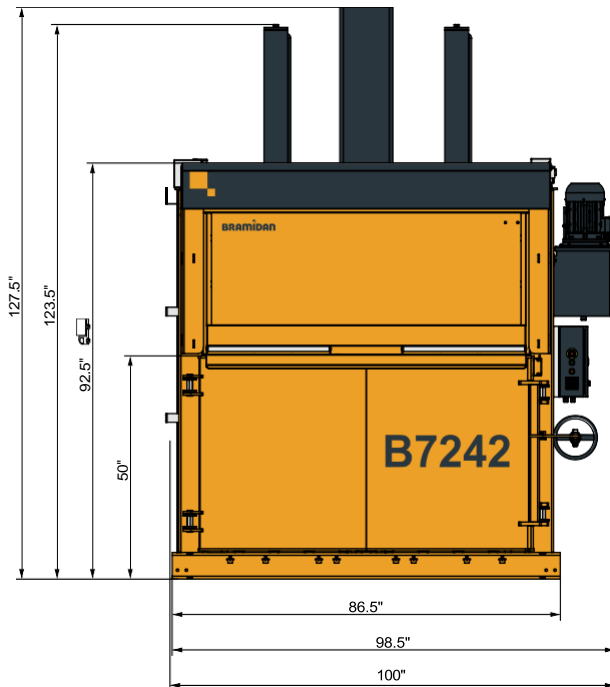

Technical specifications

Bale size WxDxH (inch) 72 x 42 x 48

Feed opening WxH (inch) 72 x 23

Power supply 208/230/480V 3-phase

Motor (HP) 8.9

Cycle time avg. (sec) 22

Dimensions WxDxH (inch) 100 x 66 x 128 / 93

Machine weight (lbs) 7,100

Stroke (inch) 36

Number of ties 8

Type of tying Twine / Steel wire

Full bale light Yes

Bale eject Automatic



Bale weight
Cardboard (lbs) 1400-1700

Plastic foil (lbs) 1400-1700



Press force 110,000 lbs



Noise level 62-64 dB



Waste types
Cardboard, plastic foil, paper.

Bay Area Trash Compactor
2310 Tice Valley Blvd.
Walnut Creek, CA 94595
(925) 465-5133
www.BATC-Compacts.com

