



Compacting EPE

Technical data specification for SK370

Dimensional drawing

Subject to technical modifications.

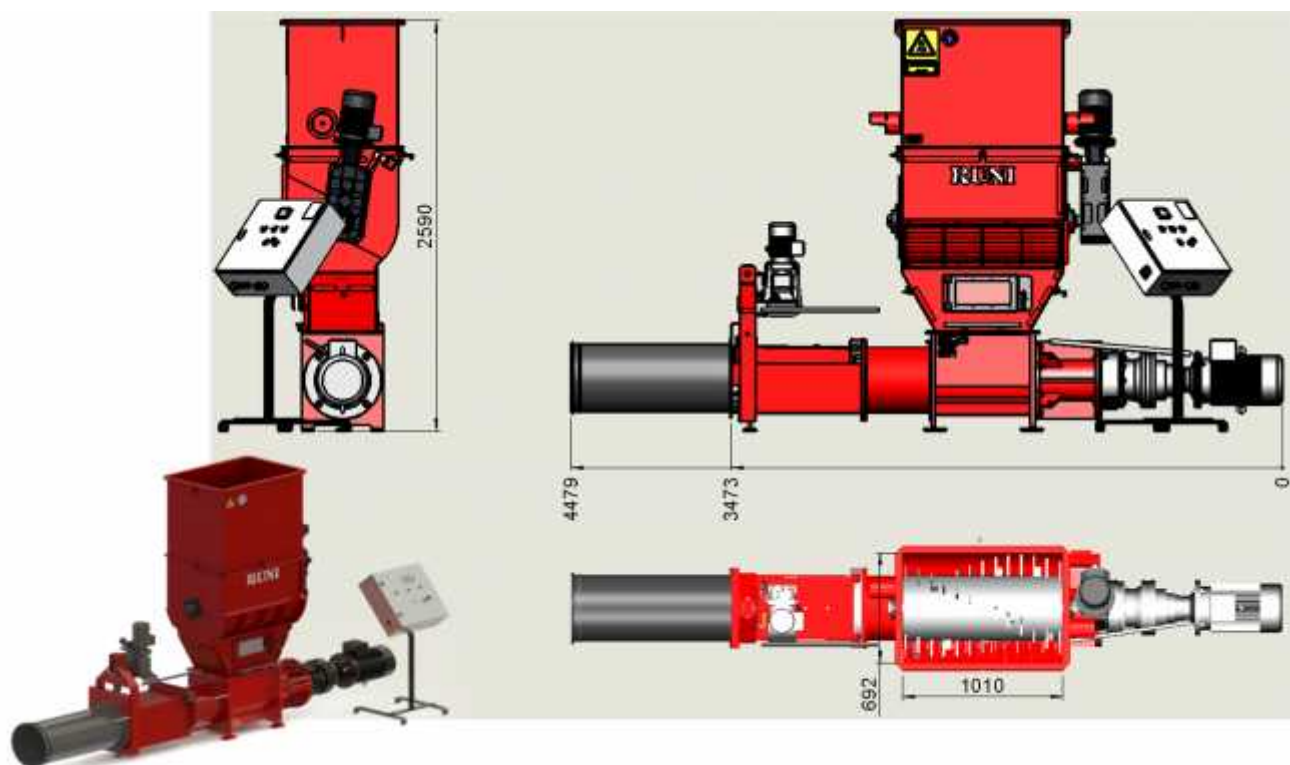

Technical data	Europe	USA
Material	EPE	EPE
Achieved density *)	500 kg/m ³	30 lbs/ft ³
Capacity per hour *)	250 kg	550 lbs
Daily capacity *)	5000 kg	5 ton
Diameter for outlet	370 mm	14,5 inch
Feed-opening dimension, inlet (standard)	1000x500 mm	40 x 20 inch
Weight	1500 kg	3,300 lbs
Machine dimension (LxWxH) (standard)	4479 x 760 x 2590 mm	176 x 30 x 102 inch
Motor power	Main motor: 15 kW Hydraulic pump: 0,55 kW Pre-cutter: 3 kW	Main motor: 24 hp (18 kW) Hydraulic pump: 0,88 hp (0,66 kW) Pre-cutter: 5 hp (3,6 kW)
Power supply	3 x 400V, 50Hz, 63A	3 x 480V, 60Hz, 63A
Marking	CE-approved	CE-approved, UL

*) Depending on the density of the material.



Compacting EPE

Description

EPE (expanded polyethylen) known as packaging material for sensitive products such as glass and electronics. With RUNI SK370 screw compactor and a special developed pre-cutter, EPE can be compacted into a cylinder shaped block with a density of up to 500 kg/m³. In cases where it only concerns smaller EPE pieces it will most likely not be necessary with the pre-cutter. The compacted EPE can be sold for recycling.

TURN WASTE TO VALUE!



Function

The EPE is fed into the pre-cutter and cut into smaller pieces. The screw and the automatic hydraulic jaws will compact the material into uniform blocks. The incorporated sensors ensure easy operation with automatic start and stop function. For some types of EPE – typically EPE with a small cell structure will re-expand when it leaves the machine. In these cases we recommend compacting into endless plastic bags.



Benefits

- Generate income of compacted EPE
- Reduce cost for warehouse, transport and disposal.
- Reduce manual labour.
- Safe and easy operation with automatic start and stop.

Option

-) Pre-cutter.
-) Bagholder for compacting EPE directly into plastic bags.