



# B20

## VERTICAL BALER



### BENEFITS

- Safety - Bramidan balers are the safest balers on the market
- Longevity - Many Bramidan balers have been operating daily for over 20 years
- Warranty - 1 year labor, 2 year parts, 3 years on the frame

### FEATURES

- Ease of use - All wire and twine is pre-fed while the baler is empty
- Ergonomically superior - No reaching behind the baler
- Quiet - at 60-68 Db you'll hardly hear a Bramidan operate
- Automatic bale ejection
- Indicator lights highlight baler functions
- **Free** data cellular communication



The wide feed opening on the B20 is ideal for large cardboard boxes, plastic shrink wrap, and paper. Retainer dogs inside of the chamber keep material compacted.

## SMART APPROACH

- Text/email sent when baler is full
- Text/email to your recycler after a desired number of bales produced
- Sustainability reporting – track how many bales you produce
- Remote service/troubleshooting

manufactured by **BRAMIDAN**<sup>®</sup>



(925) 465-5133 | [info@batc-compacts.com](mailto:info@batc-compacts.com) | [www.batc-compacts.com](http://www.batc-compacts.com)

© 2019



# B20

## VERTICAL BALER

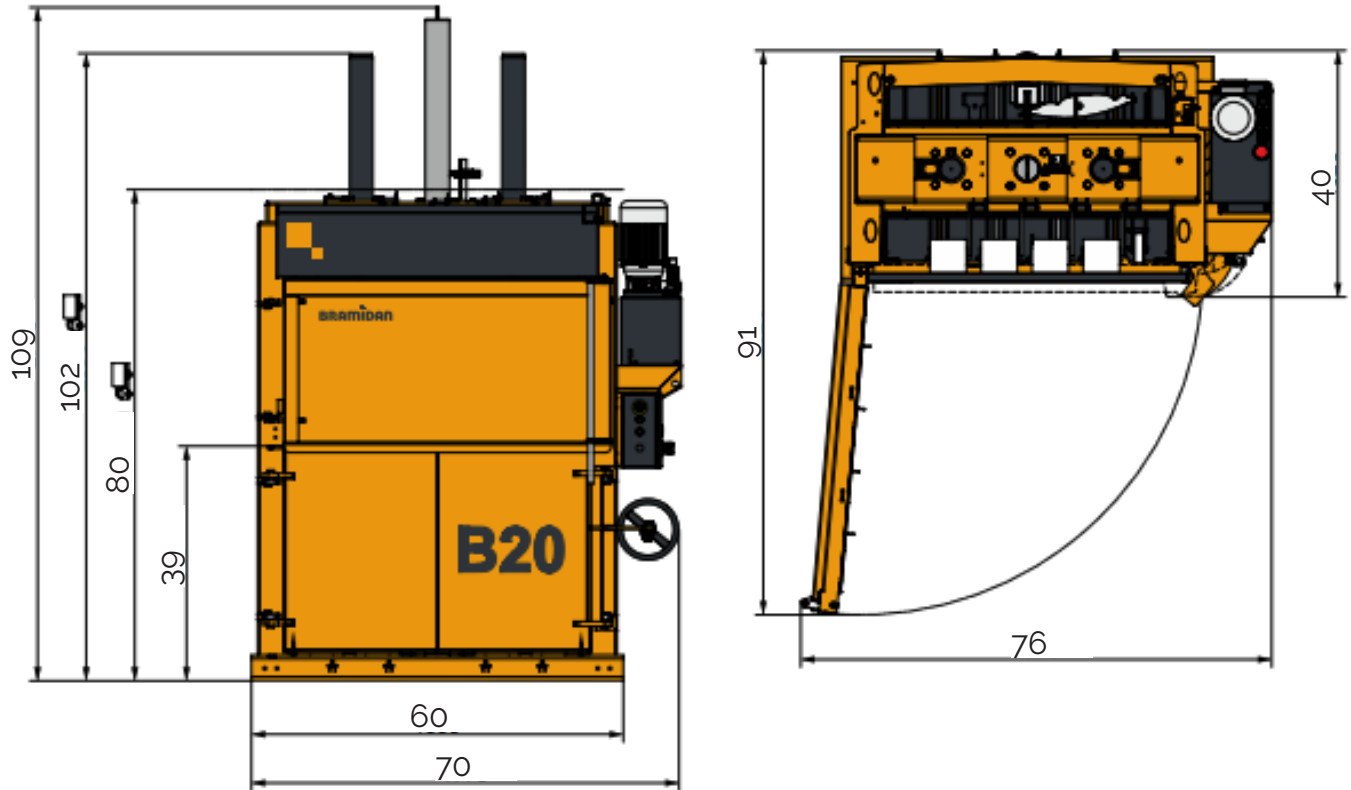

### SPECIFICATIONS

Press force (lbs)	44,100
Power supply	208/230/480V 3-phase
Motor (HP)	5.5
Noise level (dB)	62-64
Cycle time (sec)	27
Dimensions (WxDxH) (in)	69x41x109/80
Weight (lbs)	2,750
Feed opening WxH (in)	48x22
Load height (in)	38
Chamber height	56
Stroke (in)	30
Bale size (WxDxH0)	48x30x30
Bale weight OCC (lbs)	450-550
Bale weight plastics (lbs)	550-650

\*Specifications may vary 

manufactured by **BRAMIDAN**<sup>®</sup>



(925) 465-5133 | [info@batc-compacts.com](mailto:info@batc-compacts.com) | [www.batc-compacts.com](http://www.batc-compacts.com)

© 2019