



X30 HD

VERTICAL BALER

BENEFITS

- Safety - Bramidan balers are the safest balers on the market
- Longevity - Many Bramidan balers have been operating daily for over 20 years
- Warranty - 1 year labor, 2 year parts, 3 years on the frame

FEATURES

- Ease of use - All wire and twine is pre-fed while the baler is empty
- Ergonomically superior - No reaching behind the baler
- Quiet - at 60-68 Db you'll hardly hear a Bramidan operate
- Automatic bale ejection
- Indicator lights highlight baler functions
- **Free** data cellular communication

A high-capacity baler with a large feed opening to easily accommodate bulky boxes and expandable plastics.

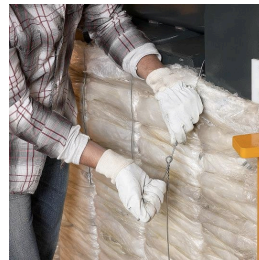
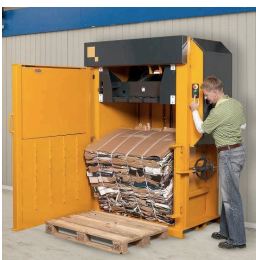

SMART APPROACH

- Text/email sent when baler is full
- Text/email to your recycler after a desired number of bales produced
- Sustainability reporting – track how many bales you produce
- Remote service/troubleshooting

manufactured by **BRAMIDAN**[®]



(925) 465-5133 | info@batc-compacts.com | www.batc-compacts.com

© 2019



X30 HD

VERTICAL BALER

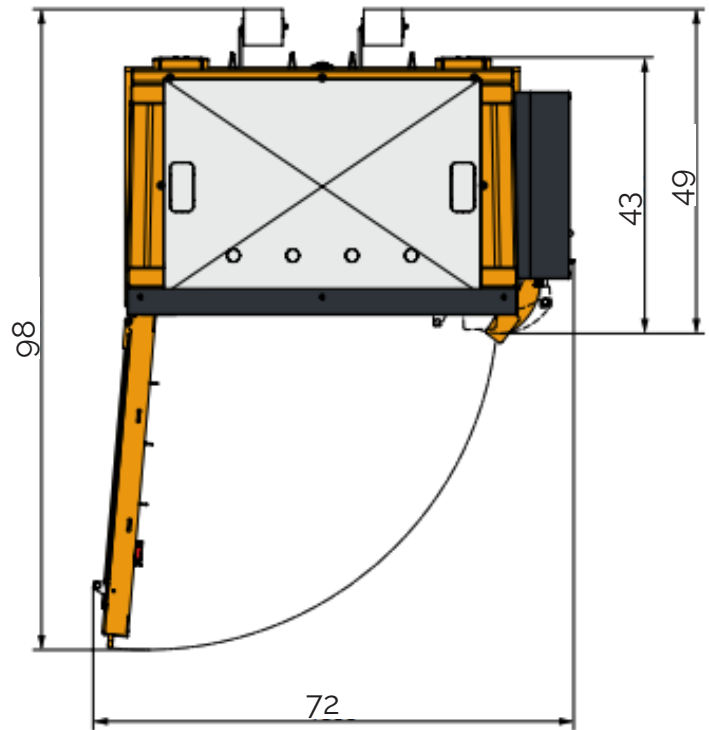
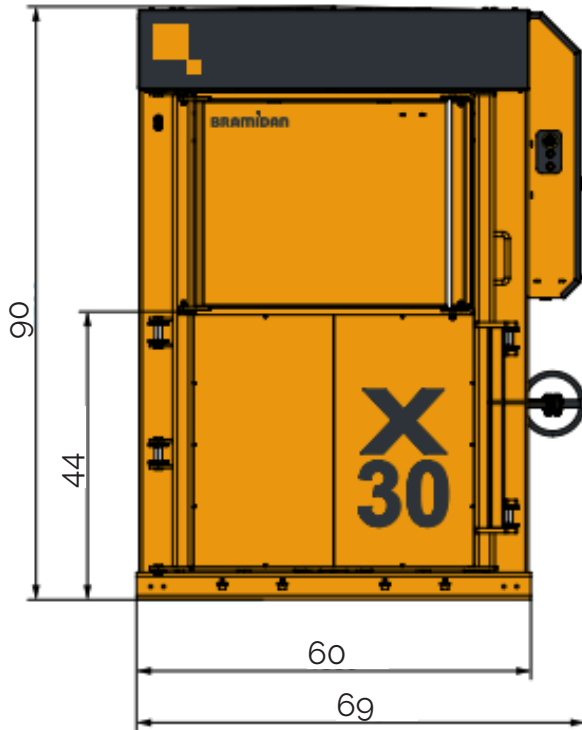

SPECIFICATIONS

Bale size WxDxH (in)	47x31x39
Feed opening WxH (in)	43x26
Power supply	3x400V 50Hz 16A
Motor (kW)	4
Cycle time (sec)	25
Dimensions (WxDxH) (in)	69x49x90
Weight (lbs)	3,770
Stroke (in)	37
Number of ties	4
Type of tying	Twine/steel wite
Full bale light	Yes
Bale eject	Automatic
Press force (t)	30
Bale weight (cardboard)	600-770
Noise level (dB)	59-60

*Specifications may vary 

manufactured by **BRAMIDAN**[®]



(925) 465-5133 | info@batc-compacts.com | www.batc-compacts.com

© 2019