



X10 HD

VERTICAL BALER



BENEFITS

- Safety - Bramidan balers are the safest balers on the market
- Longevity - Many Bramidan balers have been operating daily for over 20 years
- Warranty - 1 year labor, 2 year parts, 3 years on the frame

FEATURES

- Ease of use - All wire and twine is pre-fed while the baler is empty
- Ergonomically superior - No reaching behind the baler
- Quiet - at 60-68 Db you'll hardly hear a Bramidan operate
- Automatic bale ejection
- Indicator lights highlight baler functions
- **Free** data cellular communication

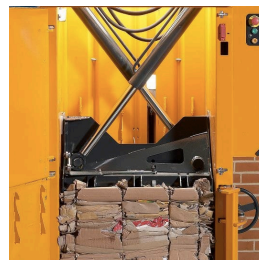
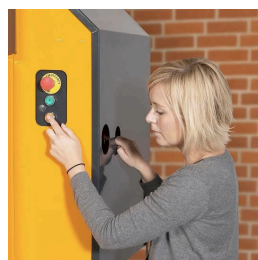
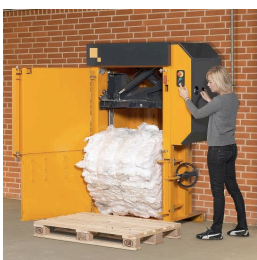

A high-capacity baler with a small footprint and an impressive 22,000 lbs. of press force.

SMART APPROACH

- Text/email sent when baler is full
- Text/email to your recycler after a desired number of bales produced
- Sustainability reporting – track how many bales you produce
- Remote service/troubleshooting

manufactured by **BRAMIDAN**[®]



(925) 465-5133 | info@batc-compacts.com | www.batc-compacts.com

© 2019



X10 HD

VERTICAL BALER

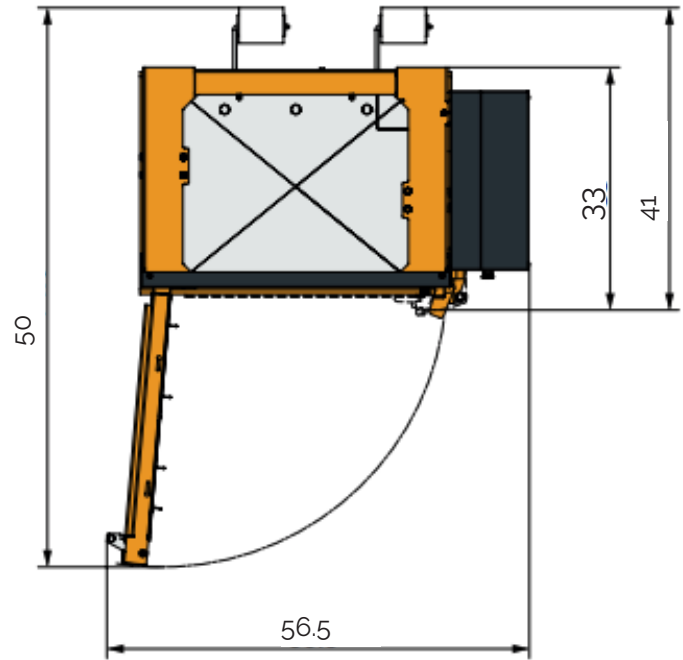
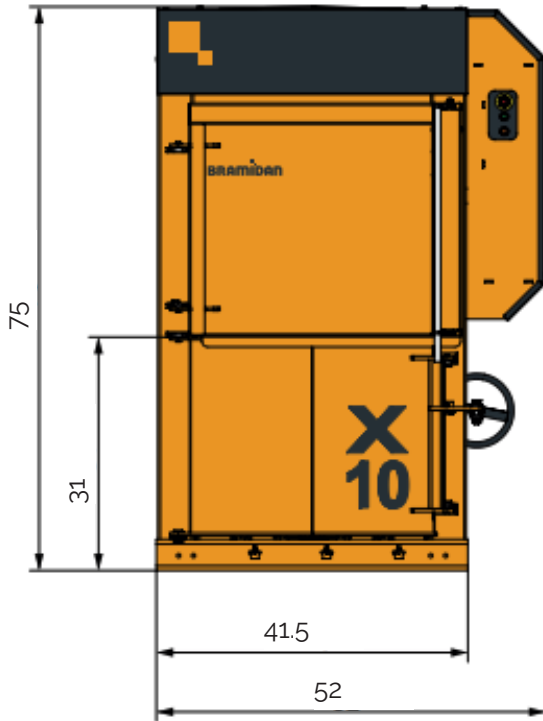

SPECIFICATIONS

Press force (lbs)	22,000
Noise level	62-64 dB
Bale weight cardboard (lbs)	150-200
Bale weight plastic (lbs)	175-245
Bale size (WxDxH)	30x24x24
Feed opening (WxH)	31x24
Motor (HP)	5.5
Cycle time (sec)	40
Dimensions (WxDxH)	52x41x75
Machine weight (lbs)	1,470
Stroke (in)	33
Number of ties	3
Type of tying	Twine
Full bale light	yes
Bale eject	Automatic

*Specifications may vary 

manufactured by **BRAMIDAN**[®]



(925) 465-5133 | info@batc-compacts.com | www.batc-compacts.com

© 2019