

Poly Dura Kart container features:

Quality Products since 1945

Dimensions

	65 Gallons	96 Gallons
• Overall Height	41"	43.5"
• Overall Depth	32"	35.5"
• Overall Width	26"	29.7"
• Wheel Diameter	10"	10"
• Axle Diameter	7/8"	7/8"
• Container Capacity	65	96
• Load Rating (lbs)	224	336
• Approximate Weight	40 lbs	50 lbs

Truckload Quantities

Size	Stack	48" Trailer	53" Trailer
65 Gallon	6	252	288
96 Gallon	6	228	252

Standard Features

- Clean dumping, maintenance free interior
- Rotational molded containers from LLDPE/MDPE material for greater, dent and impact resistance
- Domed lid for strength and water deflection
- Molded in steel latch bars
- Custom color matches are available
- Compatible with both fully automated and semi - automated lifters.
- Backed with a 10 year warranty
- Molded in multi-lingual instructions
- Bottom wear pads for abrasion
- Containers come completely assembled and nestable for shipping

Schematics

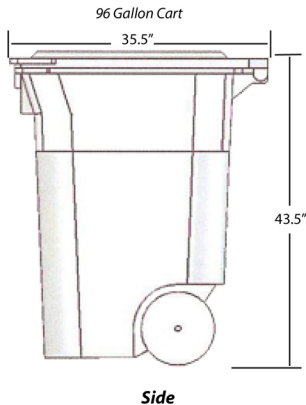
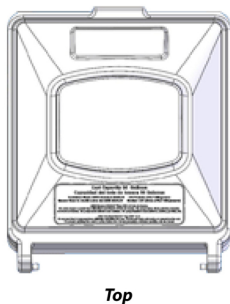
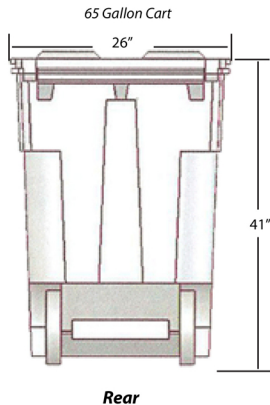

All sizes are approximate, materials and product improvement is a continuous commitment a Nedland Industries.
These specifications subject to change without notice.

Meets ANSI standards Z245.30 & Z245.60 Type B/G cart