

# Features

## Steering system

- Proportional speed control varies truck speed automatically in relation to tiller-arm angle for safe, comfortable and productive operation
- A creep speed button ensures high maneuverability in confined areas when operating at low speeds with the tiller-arm in the upright position
- End-of-stroke resistance on the tiller-arm avoids accidental, abrupt braking
- Soft fold-back slows down the tiller-arm when returning to upright position

## Working station & Display

- Wide, deep storage compartment for shrink wrap, pens, markers etc.
- Strong plastic Exxtral® motor and battery cover
- Multifunction display as standard with hourmeter, maintenance indication, battery discharge indicator, fault code indication

## Tiller-arm & Control handle

- The ergonomic Grivory® material ensures effortless operation
- Wrap-around hand protection
- Comfortable controls, operable with either hand and gloves

## Chassis & Forks

- Compact, rounded shape
- Strong, robust steel construction
- Low chassis skirt to protect operator's feet
- Cast steel fork tips
- Large caster wheels with shock absorbers for stability on ramps and uneven floors

## AC motor & Booster effect

- Powerful, smooth-running AC motor, 1.2kW (at 100% output)
- Traction speed adjustable
- Booster effect provides momentary torque increase
- No roll-back on hill starts
- Gradient performance: 24% unladen, 10% with full load



## Braking system

- Highly efficient electromagnetic brake applied by moving the tiller-arm to fully up or down position
- Automatic deceleration when releasing traction butterfly or reversing direction
- Truck slows before coming to a stop, remaining under total control at all times



## Batteries and Chargers

- Vertical battery change
- Battery capacities from 150 Ah to 375 Ah



## Maintenance and CAN-bus technology

- Zero maintenance, moisture and dust-proof AC motors
- CAN-bus technology enables fast, easy access to all truck data
- Individually adjustable operating parameters
- Quick and convenient access to all components



## Electric Pallet Trucks 4400 lb. Capacity T20

SERIES 1152

Linde Material Handling

## Safety

Linde engineers have designed this new pallet truck around the concept of active and passive safety. Passive safety demands that edges are smooth and rounded; that the battery compartment is covered and that the power cable is routed inside to avoid snagging. Standard caster wheels keep the truck stable while maneuvering in tight areas and add to active safety during operation.

## Performance

The combination of AC motor technology and Linde LAC digital control makes these pallet trucks highly productive. Operating parameters can be adjusted to match customer requirements and application. When additional power is needed, an automatic momentary power boost provides higher torque to overcome an obstacle. Standard, hardened steel, entry and exit rollers ensure quickest possible pallet pickup and drop-off. In addition, a very practical "creep speed button" allows utmost maneuverability in confined areas. The unique "proportional speed system" will automatically regulate travel speed according to the tiller angle.

## Comfort

Through the application of Sinergo®, an innovative, all inclusive, design concept, which incorporates every aspect of operator and truck interface, all controls on the ergonomically shaped tiller

ANSI: Standard truck meets all applicable mandatory requirements of ANSI/T15.6 B56.1 standards for powered industrial trucks.  
NOTE: Performance data may vary due to motor and system efficiency tolerances. The performance depicted represents nominal values obtained under typical operating conditions. All metric dimensions are in millimeters unless otherwise specified. All metric dimensions are not direct equivalents due to rounding data. The descriptions and specifications included on this data sheet were in effect at the time of printing. Linde Material Handling North America Corporation reserves the right to make improvements and changes in specification or design without notice and without incurring obligation. Please check with your authorized Linde dealer for information on possible updates or revisions.

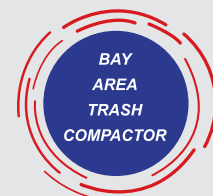

**Bay Area Trash Compactor**  
2310 Tice Valley Blvd.  
Walnut Creek, CA 94595  
1.800.955.0866  
www.BATC-Compacts.com

Linde Material Handling

# Technical Data

December 2011 SERIES 1152 (T20)

	Characteristics			Linde	
				T20 (USA)	
1.1	Manufacturer			Linde	
1.2	Model designation			T20 (USA)	
1.3	Power unit			Battery	
1.4	Operation			Pedestrian	
1.5	Load capacity	Q	lb.   kg	4400	2000
1.6	Load center	C	in.   mm	24	600
1.8	Axle center to fork face	X	in.   mm	34.5 / 37.8 <sup>1)2)</sup>	876 / 960 <sup>1)2)</sup>
1.9	Wheelbase	y	in.   mm	56.6 / 59.2 <sup>1)2)</sup>	1437 / 1503 <sup>1)2)</sup>
2.1	Service weight		lb.   kg	972 <sup>3)</sup>	441 <sup>3)</sup>
2.2	Axle load with load, front/rear		lb.   kg	1782 / 3562 <sup>3)</sup>	809/1616 <sup>3)</sup>
2.3	Axle load without load, front/rear		lb.   kg	754 / 218 <sup>3)</sup>	342 / 99 <sup>3)</sup>
3.1	Tires (C = cushion - solid rubber, P = Polyurethane)			C + P <sup>4)</sup>	
3.2	Tire size, drive wheels		in.   mm	9.1 x 3.5	230 x 90
3.3	Tire size, load wheels		in.   mm	3.1 x 4.1	80 x 105
3.4	Caster wheels		in.   mm	4.9 x 1.6	125 x 40
3.5	Wheels, number of drive wheels (x = driven)			1x + 2	1x + 2
3.6	Track width, caster wheels	b10	in.   mm	19.0 <sup>1)</sup>	482 <sup>1)</sup>
3.7	Track width, load wheels	b11	in.   mm	15.6 / 20.3 <sup>1)</sup>	395 / 515 <sup>1)</sup>
4.4	Lift	h3	in.   mm	4.9 <sup>1)</sup>	125 <sup>1)</sup>
4.9	Height of tiller arm in operating position, min/max	h14	in.   mm	29.1 / 47.6	740 / 1208
4.15	Fork height, lowered	h13	in.   mm	3.2	83
4.19	Overall length	L1	in.   mm	69.9 <sup>1)</sup>	1775 <sup>1)</sup>
4.20	Length to fork face	L	in.   mm	22.6 <sup>1)</sup>	575 <sup>1)</sup>
4.21	Overall width	b1/b2	in.   mm	28.3 <sup>1)</sup>	720 <sup>1)</sup>
4.22	Fork dimensions	S/e/L	in.   mm	6.5 x 2.2 x 47.3	165 x 55 x 1200
4.25	Fork spread, min/max	b5	in.   mm	22.0 / 26.8 <sup>1)</sup>	560 / 680 <sup>1)</sup>
4.32	Ground clearance, center of wheelbase	m2	in.   mm	1.3 / 6.3 <sup>2)</sup>	33 / 158 <sup>2)</sup>
4.34	Aisle width with 48" pallet	Ast	in.   mm	83.9 <sup>5)</sup>	2129 <sup>5)</sup>
4.35	Turning radius	Wa	in.   mm	62.4 / 65.2 <sup>2)5)</sup>	1585 / 1655 <sup>2)5)</sup>
5.1	Travel speed, with/without load		mph   km/h	3.5 / 3.5	5.6 / 5.6
5.8	Maximum climbing ability, with/without load		%	10 / 24	
5.9	Acceleration time, with/without load		s	7.6 / 6.4	
6.1	Drive motor, 60 minute rating		hp   kW	1.6	1.20
6.2	Lift motor rating at 15%		hp   kW	1.6	1.20
6.3	Battery compartment size, l x w x h		in.   mm	9.2 x 25.7 x 24.8	235 x 654 x 630
6.4	Battery voltage		V	24	
6.5	Battery weight (± 5%)		lb.   kg	400	181
8.1	Type of drive control			LAC	LAC
8.4	Noise level at operator's ear		dB(A)	<70	<70

# Standard equipment / Optional equipment

## Standard Equipment

Sinergo®, operator / truck interface

- Tiller-arm with low mounting point
- Exxtral® motor and battery compartment cover
- Creep speed control
- Proportional speed control
- End-of-stroke tiller-arm dampening
- Storage compartments

Multifunction display with hourmeter, maintenance indicator, battery discharge indicator and internal fault code display

AC motor

Linde LAC controller

Key switch

Horn

CAN-bus technology

Electromagnetic brake

Automatic parking brake

Cushion rubber drive wheel

Single polyurethane load wheels

Fork length: 47" (nominal)

Width across forks: 27" (nominal)

Standard protection to 20°F

Pallet entry and exit rollers

Caster wheels

## Optional equipment

Drive wheels (variations)

Alternative fork lengths and widths

Load backrest

Pin code access

Cold storage protection

Check with dealer/factory for additional equipment availability.

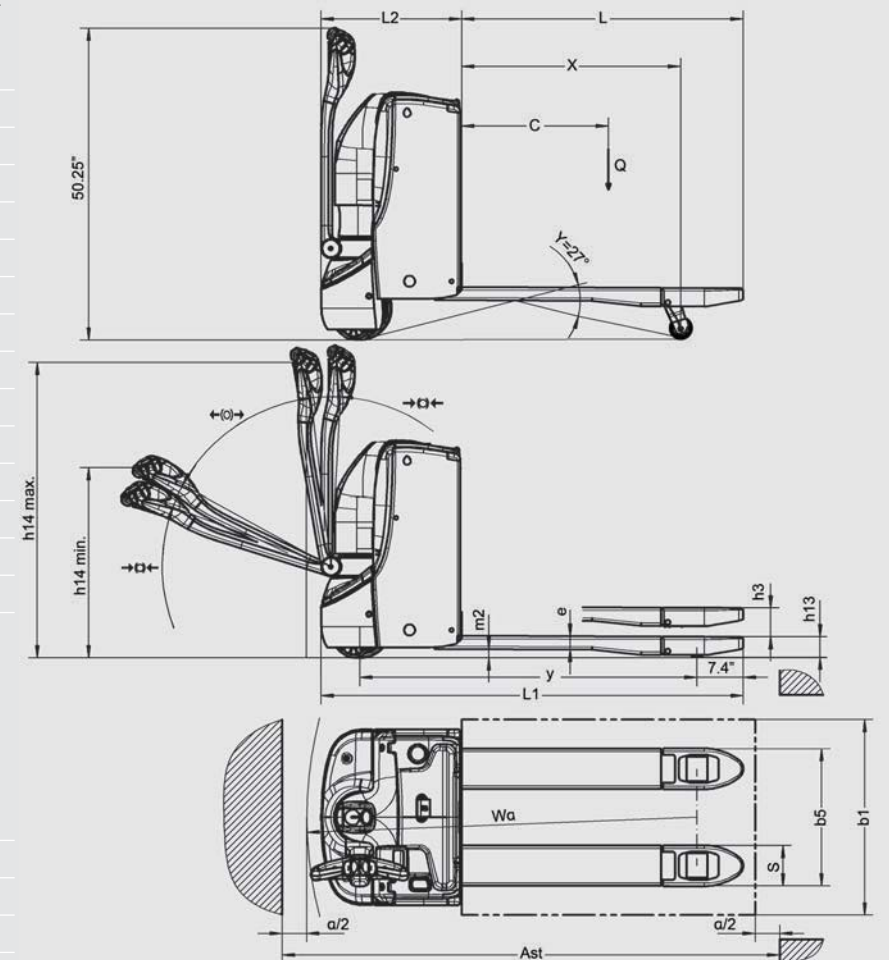

1) (± 5 mm)  
 2) Forks raised / lowered  
 3) (± 10%)  
 4) Cushion - solid rubber + polyurethane  
 5) With creep speed = tiller in vertical position, includes 8 inch operating clearance

# Technical Data

December 2011 SERIES 1152 (T20)

	Characteristics				Linde	
					T20 (USA)	
1.1	Manufacturer				Battery	
1.2	Model designation				Pedestrian	
1.3	Power unit				4400	2000
1.4	Operation				24	600
1.5	Load capacity	Q	lb.	kg	34.5 / 37.8 <sup>1)2)</sup>	876 / 960 <sup>1)2)</sup>
1.6	Load center	C	in.	mm	56.6 / 59.2 <sup>1)2)</sup>	1437 / 1503 <sup>1)2)</sup>
1.8	Axle center to fork face	X	in.	mm	972 <sup>3)</sup>	441 <sup>3)</sup>
1.9	Wheelbase	y	in.	mm	1782 / 3562 <sup>3)</sup>	809 / 1616 <sup>3)</sup>
2.1	Service weight		lb.	kg	754 / 218 <sup>3)</sup>	342 / 99 <sup>3)</sup>
2.2	Axle load with load, front/rear		lb.	kg	C + P <sup>4)</sup>	
2.3	Axle load without load, front/rear		lb.	kg	9.1 x 3.5	230 x 90
3.1	Tires (C = cushion - solid rubber, P = Polyurethane)				3.1 x 4.1	80 x 105
3.2	Tire size, drive wheels		in.	mm	4.9 x 1.6	125 x 40
3.3	Tire size, load wheels		in.	mm	1x + 2	1x + 2
3.4	Caster wheels		in.	mm	19.0 <sup>1)</sup>	482 <sup>1)</sup>
3.5	Wheels, number of drive wheels (x = driven)				15.6 / 20.3 <sup>1)</sup>	395 / 515 <sup>1)</sup>
3.6	Track width, caster wheels	b10	in.	mm	4.9 <sup>1)</sup>	125 <sup>1)</sup>
3.7	Track width, load wheels	b11	in.	mm	29.1 / 47.6	740 / 1208
4.4	Lift	h3	in.	mm	3.2	83
4.9	Height of tiller arm in operating position, min/max	h14	in.	mm	69.9 <sup>1)</sup>	1775 <sup>1)</sup>
4.15	Fork height, lowered	h13	in.	mm	22.6 <sup>1)</sup>	575 <sup>1)</sup>
4.19	Overall length	L1	in.	mm	28.3 <sup>1)</sup>	720 <sup>1)</sup>
4.20	Length to fork face	L	in.	mm	6.5 x 2.2 x 47.3	165 x 55 x 1200
4.21	Overall width	b1/b2	in.	mm	22.0 / 26.8 <sup>1)</sup>	560 / 680 <sup>1)</sup>
4.22	Fork dimensions	S/e/L	in.	mm	1.3 / 6.3 <sup>2)</sup>	33 / 158 <sup>2)</sup>
4.25	Fork spread, min/max	b5	in.	mm	83.9 <sup>5)</sup>	2129 <sup>5)</sup>
4.32	Ground clearance, center of wheelbase	m2	in.	mm	62.4 / 65.2 <sup>2)5)</sup>	1585 / 1655 <sup>2)5)</sup>
4.34	Aisle width with 48" pallet	Ast	in.	mm	3.5 / 3.5	5.6 / 5.6
4.35	Turning radius	Wa	in.	mm	10 / 24	
5.1	Travel speed, with/without load		mph	km/h	7.6 / 6.4	
5.8	Maximum climbing ability, with/without load			%	1.6	1.20
5.9	Acceleration time, with/without load			s	1.6	1.20
6.1	Drive motor, 60 minute rating		hp	kW	9.2 x 25.7 x 24.8	235 x 654 x 630
6.2	Lift motor rating at 15%		hp	kW	24	
6.3	Battery compartment size, l x w x h		in.	mm	400	181
6.4	Battery voltage		V		LAC	LAC
6.5	Battery weight (± 5%)		lb.	kg	<70	<70
8.1	Type of drive control					
8.4	Noise level at operator's ear			dB(A)		

# Standard equipment / Optional equipment

## Standard Equipment

Sinergo®, operator / truck interface

- Tiller-arm with low mounting point
- Exxtral® motor and battery compartment cover
- Creep speed control
- Proportional speed control
- End-of-stroke tiller-arm dampening
- Storage compartments

Multifunction display with hourmeter, maintenance indicator, battery discharge indicator and internal fault code display

AC motor

Linde LAC controller

Key switch

Horn

CAN-bus technology

Electromagnetic brake

Automatic parking brake

Cushion rubber drive wheel

Single polyurethane load wheels

Fork length: 47" (nominal)

Width across forks: 27" (nominal)

Standard protection to 20°F

Pallet entry and exit rollers

Caster wheels

## Optional equipment

Drive wheels (variations)

Alternative fork lengths and widths

Load backrest

Pin code access

Cold storage protection

Check with dealer/factory for additional equipment availability.

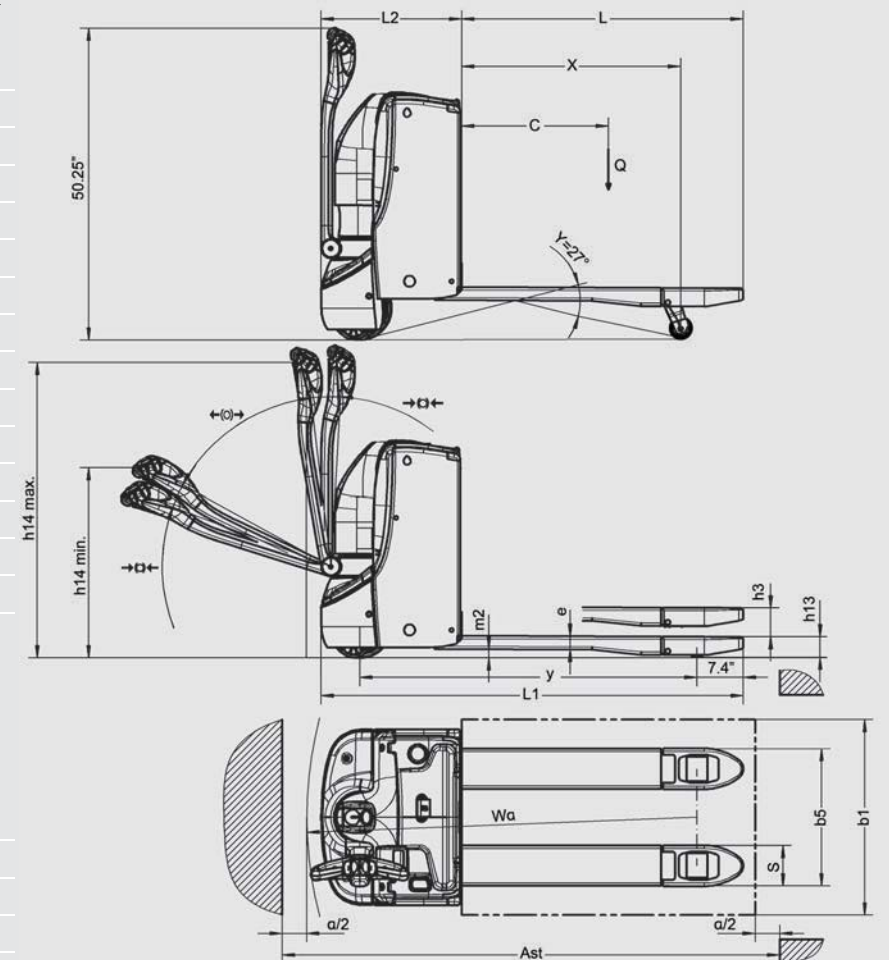

1) (± 5 mm)  
 2) Forks raised / lowered  
 3) (± 10%)  
 4) Cushion - solid rubber + polyurethane  
 5) With creep speed = tiller in vertical position, includes 8 inch operating clearance

# Features

## Steering system

- Proportional speed control varies truck speed automatically in relation to tiller-arm angle for safe, comfortable and productive operation
- A creep speed button ensures high maneuverability in confined areas when operating at low speeds with the tiller-arm in the upright position
- End-of-stroke resistance on the tiller-arm avoids accidental, abrupt braking
- Soft fold-back slows down the tiller-arm when returning to upright position

## Working station & Display

- Wide, deep storage compartment for shrink wrap, pens, markers etc.
- Strong plastic Exxtral® motor and battery cover
- Multifunction display as standard with hourmeter, maintenance indication, battery discharge indicator, fault code indication

## Tiller-arm & Control handle

- The ergonomic Grivory® material ensures effortless operation
- Wrap-around hand protection
- Comfortable controls, operable with either hand and gloves

## Chassis & Forks

- Compact, rounded shape
- Strong, robust steel construction
- Low chassis skirt to protect operator's feet
- Cast steel fork tips
- Large caster wheels with shock absorbers for stability on ramps and uneven floors

## AC motor & Booster effect

- Powerful, smooth-running AC motor, 1.2kW (at 100% output)
- Traction speed adjustable
- Booster effect provides momentary torque increase
- No roll-back on hill starts
- Gradient performance: 24% unladen, 10% with full load



## Braking system

- Highly efficient electromagnetic brake applied by moving the tiller-arm to fully up or down position
- Automatic deceleration when releasing traction butterfly or reversing direction
- Truck slows before coming to a stop, remaining under total control at all times



## Batteries and Chargers

- Vertical battery change
- Battery capacities from 150 Ah to 375 Ah



## Maintenance and CAN-bus technology

- Zero maintenance, moisture and dust-proof AC motors
- CAN-bus technology enables fast, easy access to all truck data
- Individually adjustable operating parameters
- Quick and convenient access to all components



## Electric Pallet Trucks 4400 lb. Capacity T20

SERIES 1152

Linde Material Handling

## Safety

Linde engineers have designed this new pallet truck around the concept of active and passive safety. Passive safety demands that edges are smooth and rounded; that the battery compartment is covered and that the power cable is routed inside to avoid snagging. Standard caster wheels keep the truck stable while maneuvering in tight areas and add to active safety during operation.

## Performance

The combination of AC motor technology and Linde LAC digital control makes these pallet trucks highly productive. Operating parameters can be adjusted to match customer requirements and application. When additional power is needed, an automatic momentary power boost provides higher torque to overcome an obstacle. Standard, hardened steel, entry and exit rollers ensure quickest possible pallet pickup and drop-off. In addition, a very practical "creep speed button" allows utmost maneuverability in confined areas. The unique "proportional speed system" will automatically regulate travel speed according to the tiller angle.

## Comfort

Through the application of Sinergo®, an innovative, all inclusive, design concept, which incorporates every aspect of operator and truck interface, all controls on the ergonomically shaped tiller

ANSI: Standard truck meets all applicable mandatory requirements of ANSI/T15.6-1 standards for powered industrial trucks.  
NOTE: Performance data may vary due to motor and system efficiency tolerances. The performance depicted represents nominal values obtained under typical operating conditions. All metric dimensions are in millimeters unless otherwise specified. All metric dimensions are not direct equivalents due to rounding data. The descriptions and specifications included on this data sheet were in effect at the time of printing. Linde Material Handling North America Corporation reserves the right to make improvements and changes in specification or design without notice and without incurring obligation. Please check with your authorized Linde dealer for information on possible updates or revisions.

linde\_spec\_series 1152\_T20\_1211  
USA\_V12\_1\_020212

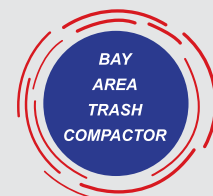

**Bay Area Trash Compactor**  
2310 Tice Valley Blvd.  
Walnut Creek, CA 94595  
1.800.955.0866  
www.BATC-Compacts.com

Linde Material Handling