

SYSTEM TEN-SIXTY

T60XDRC Automatic Baling System



The T60XDRC Baling System is the Ideal Solution For:

- Commercial Recycling Centers
- Large Institutional Applications
- Warehouses
- Shopping Centers
- Scrap Yards
- Bottle/Can Redemption Centers
- Plastic Recycling

Put the power of the System Ten-Sixty to work for you. It's the answer for high capacity, high profit solid waste recycling.

Compare these features of the T60XDRC with the competition:

- 10" cylinder produces ultra dense bales reducing shipping and handling costs
- Fast 30 second cycle time for high production
- Rear feed with conveyer and manual front feed
- Cycles automatically during conveyer loading of material
- Eliminates the need for costly material preconditioning

- Saves space over costly horizontal balers needing only 190 square feet
- Dual hydraulic bale ejectors will smoothly eject bales weighing over 3,000 pounds
- Automatic bale height shutoff with indicator light
- Available with in-ground or above-ground conveyer configuration
- Meets or exceeds all ANSI and OSHA safety standards

The T60XDRC Baling System, another great idea from Harmony Enterprises...*The Undisputed Leader in Quality Manufacturing.*



T60XDRC Automatic Baling System

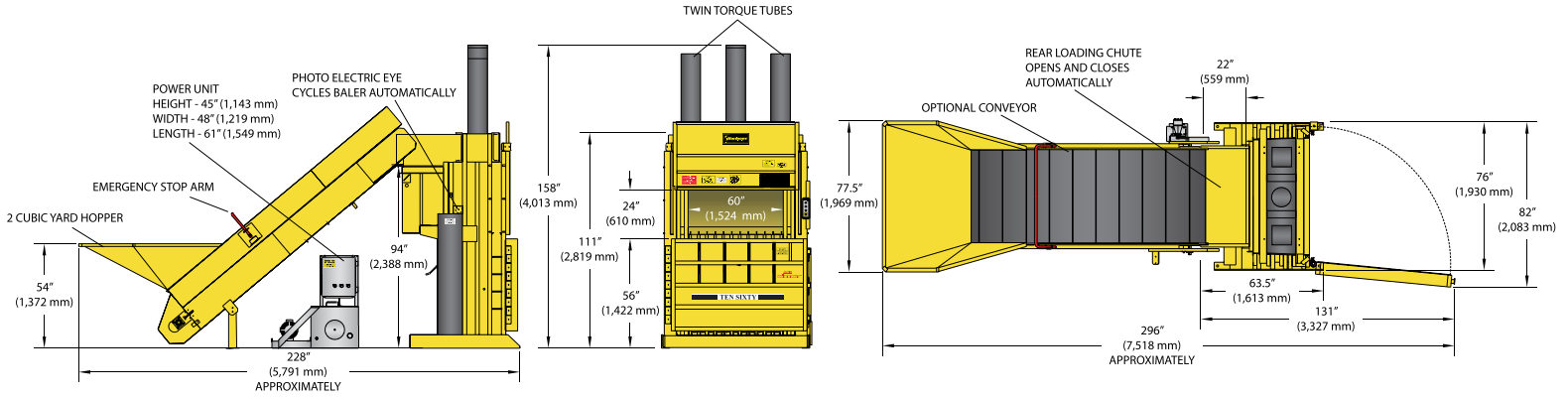

Standard T60XDRC Features:

- Available without rear chute and conveyor (T60XD)
- Features a 10" bore hydraulic cylinder with twin torque tubes
- Standard retractable bale dogs
- Eight slots to band or tie-off bales
- 2,000 pound bales are ejected smoothly with the dual hydraulic ejectors
- Cycles automatically during conveyor loading of material
- Meets or exceeds all ANSI and OSHA safety standards

MODEL	T60XDRC
Bale Size	30" x 60" x up to 48" (762 mm x 1,524 mm x up to 1,219 mm)
Ram Pressure	235,620 lbs. (106,875 kg), 150 psi
System Pressure	3,000 psi
Cycle Time	30 seconds (no load)
Cylinder	10" bore (254 mm) 52" stroke (1,321 mm)
Motor	20 horsepower, 1,750 RPM, 3 phase
Oil Reservoir	100 gallons
Pump	Heavy-duty piston
Electrical Power	208/230/460 volt, 3 phase
Bale Eject	Dual hydraulic chain

DIMENSIONS WITH CONVEYOR

Loading Door Opening	25" x 60" (635 mm x 1,524 mm)
Unloading Door Opening	56" (1,422 mm)
Overall Height	158" (4,013 mm)
Overall Depth	228" (5,791 mm)
Overall Width	76" (1,930 mm)
Conveyor Belt Width	48" (1,219 mm)
Depth with Door Open	296" (7,518 mm)
Width with Door Open	82" (2,083 mm)
Shipping Height	111" (2,819 mm)
Actual Weight	19,000 lbs. (8,618 kg)
Required Operating Area	190 square feet (17.65 square meters)

Specifications subject to change without notice.



Bay Area Trash Compactor
 2310 Tice Valley Blvd.
 Walnut Creek, CA 94595
 1.800.955.0866
www.BATC-Compacts.com